

Product Specification

Slimline Range

SM 550-VS

Vibratory Check Screener for Pneumatic Conveying

Wherever loose powders are sieved, airborne dust being generated is nearly always a problem. It is unpleasant within the working environment, and more importantly hazardous to health. The SM 550-VS has been designed to overcome this issue and provide a means of transferring and sieving product from one area to another in a single operation.

This model is vacuum only. Pressure transfer system available with larger models.

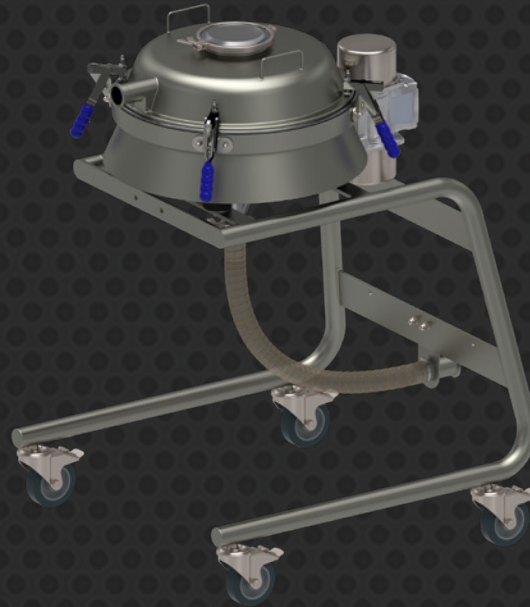

INDUSTRIES



Food & Drink



Pharmaceutical



Chemical



Nutraceutical



Reclamation & Recycling



Additive Manufacturing

FEATURES



- Enclosed system removing the issue of airborne dust
- ATEX approved on all sizes as standard
- Production sieving into conveyor, mixer or bagging machines
- Constructed from FDA compliant materials
- Dust & hose proof IP67
- Inlets/outlets sized to suit new or existing convey lines
- Mobile stands for greater flexibility
- No tool, quick change screens
- Easy clean design, no crevices
- Noise level less than 70 dBA when in use

TYPICAL MATERIALS

- Spices
- Cosmetics
- Seeds
- Liquid separation
- Pharmaceutical powders
- Most powders/ granular products
- Flour
- Crystal sugar
- Starch
- Cocoa
- Wet or dry applications

PRODUCT OPTIONS

Machine configurations*

- Upgrade to - Internal: ATEX 20 II
1D External: ATEX 22 II 3D 
- 304SS tubular handles to clamps 
- Addition of underscreen magnet assy 
- Price reduction option 
- Inlet powder entry flow type 
- Oversize outlet c/w connection to manual butterfly valve 

- Oversize outlet c/w connection to pneumatically actuated butterfly valve 
- Fluidisation to funnel cone 
- Air bleed valve after outlet 
- Ultrasonic upgrade 
- Collection bin 35L 
- Safety interlock 

*More options available on request

Finishes available

- Dressing of all external welds (with mirror polish)
- Pharmaceutical mirror polish <0.25Ra & dressing of all external welds
- Passivation after polish
- Viwateq/Sublimation finish -whole machine
- Upgrade from earth clips to external direct mesh earthing system

CERTIFIED TECHNOLOGY



Slimline Range

SM 950-VS/PS

Vibratory Check Screener for Pneumatic Conveying

Wherever loose powders are sieved, airborne dust being generated is nearly always a problem. It is unpleasant within the working environment, and more importantly hazardous to health. The SM 950-VS has been designed to overcome this issue and provide a means of transferring and sieving product from one area to another in a single operation.



SM sievemaster
by farleygreene

INDUSTRIES



Food & Drink



Pharmaceutical



Chemical



Nutraceutical



Reclamation & Recycling



Additive Manufacturing

FEATURES

- Enclosed system removing the issue of airborne dust
- ATEX approved on all sizes as standard
- Production sieving into conveyor, mixer or bagging machines
- Constructed from FDA compliant materials
- Dust & hose proof IP67
- Inlets/outlets sized to suit new or existing convey lines
- Mobile stands for greater flexibility
- No tool, quick change screens
- Easy clean design, no crevices
- Noise level less than 70 dBA when in use

TYPICAL MATERIALS

- Spices
- Cosmetics
- Seeds
- Liquid separation
- Pharmaceutical powders
- Most powders/ granular products
- Flour
- Crystal sugar
- Starch
- Cocoa
- Wet or dry applications

PRODUCT OPTIONS

Machine configurations*

- Upgrade to - Internal: ATEX 20 II
1D External: ATEX 22 II 3D



- 304SS tubular handles to clamps



- Inlet powder entry flow type



- Safety interlock



- Fluidisation to funnel cone

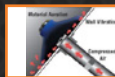

- Oversize outlet c/w connection to manual butterfly valve



- Oversize outlet c/w connection to pneumatically actuated butterfly valve



- Air bleed valve after outlet



- Ultrasonic upgrade



- Collection bin



Finishes available

- Dressing of all external welds (with mirror polish)
- Pharmaceutical mirror polish <0.25Ra & dressing of all external welds
- Passivation after polish
- Viwateq/Sublimotion finish -whole machine
- Upgrade from earth clips to external direct mesh earthing system

CERTIFIED TECHNOLOGY



*More options available on request

Slimline Range

SM 1250-VS/PS

Vibratory Check Screener for Pneumatic Conveying

Wherever loose powders are sieved, airborne dust being generated is nearly always a problem. It is unpleasant within the working environment, and more importantly hazardous to health. The SM 1250-VS has been designed to overcome this issue and provide a means of transferring and sieving product from one area to another in a single operation.

Vacuum and pressure model.



INDUSTRIES	Food & Drink	Pharmaceutical	Chemical	Nutriceutical	Reclamation & Recycling	Additive Manufacturing
------------	--------------	----------------	----------	---------------	-------------------------	------------------------

FEATURES

- | | |
|--|---|
| <ul style="list-style-type: none"> Enclosed system removing the issue of airborne dust ATEX approved on all sizes as standard Production sieving into conveyor, mixer or bagging machines Constructed from FDA compliant materials Dust & hose proof IP67 | <ul style="list-style-type: none"> Inlets/outlets sized to suit new or existing convey lines Mobile stands for greater flexibility No tool, quick change screens Easy clean design, no crevices Noise level less than 70 dBA when in use |
|--|---|

TYPICAL MATERIALS

- | | |
|--|--|
| <ul style="list-style-type: none"> Spices Cosmetics Seeds Liquid separation Pharmaceutical powders Most powders/ granular products | <ul style="list-style-type: none"> Flour Crystal sugar Starch Cocoa Wet or dry applications |
|--|--|

PRODUCT OPTIONS

Machine configurations*		
<ul style="list-style-type: none"> Upgrade to - Internal: ATEX 20 II 1D External: ATEX 22 II 3D 		<ul style="list-style-type: none"> Oversize outlet c/w connection to manual butterfly valve
<ul style="list-style-type: none"> 304SS tubular handles to clamps 		<ul style="list-style-type: none"> Oversize outlet c/w connection to pneumatically actuated butterfly valve
<ul style="list-style-type: none"> Inlet powder entry flow type 		<ul style="list-style-type: none"> Air bleed valve after outlet
<ul style="list-style-type: none"> Safety interlock 		<ul style="list-style-type: none"> Ultrasonic upgrade
<ul style="list-style-type: none"> Fluidisation to funnel cones 		<ul style="list-style-type: none"> Collection bin
<ul style="list-style-type: none"> x2 vision ports as standard 		

- Dressing of all external welds (with mirror polish)
- Pharmaceutical mirror polish <0.25Ra & dressing of all external welds
- Passivation after polish
- Vivateq/Sublimotion finish -whole machine
- Upgrade from earth clips to external direct mesh earthing system

CERTIFIED TECHNOLOGY



*More options available on request

1

THIRD ANGLE PROJECTION



2

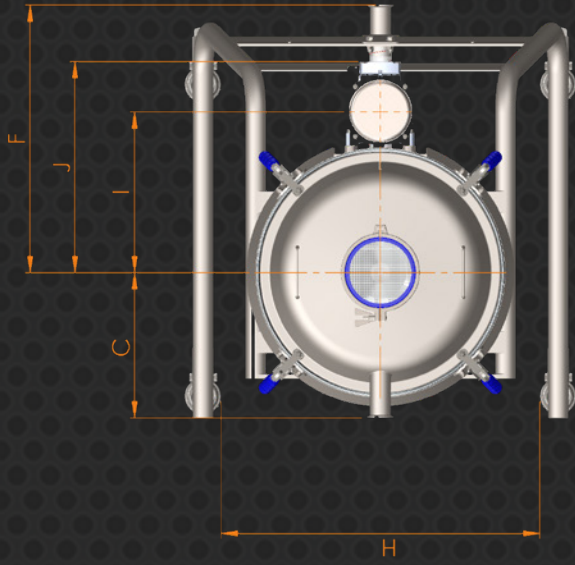

3

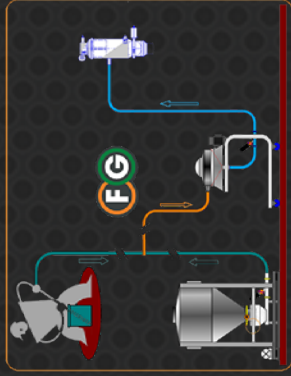

4

SM SLIMLINE 550, 950 & 1250

5

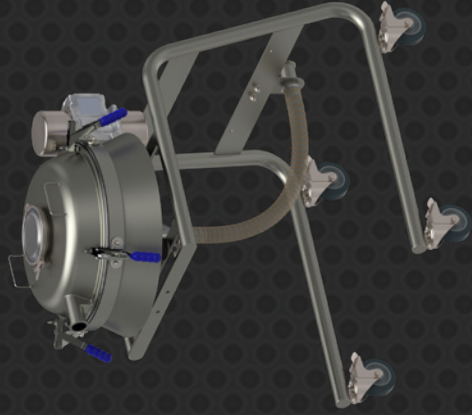

6

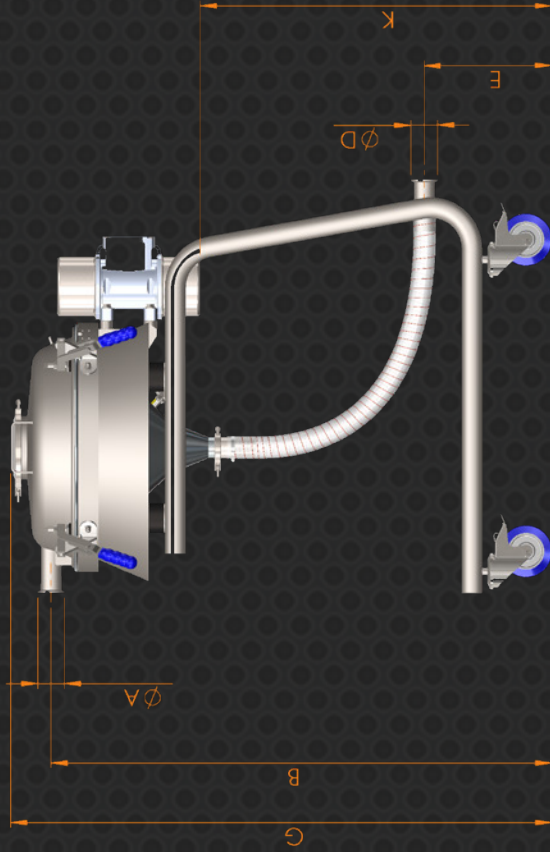

DIMENSION	
A	DN 50 DIN32676
B	1205
C	350
D	DN50 DIN32676
E	307
F	646
G	1300
H	765
I	388
J	508
K	846

ELECTRICAL	SM-550-VS
VOLTAGE	110 / 240 / 380-460
FREQUENCY	50 / 60 Hz
POWER	0.3 kW
PHASE	1 / 3
ATEX	YES

SCREEN DIAMETER = 665
 *HOSE CONNECTIONS CAN BE MADE TO MATCH LINE

1

THIRD ANGLE PROJECTION



2

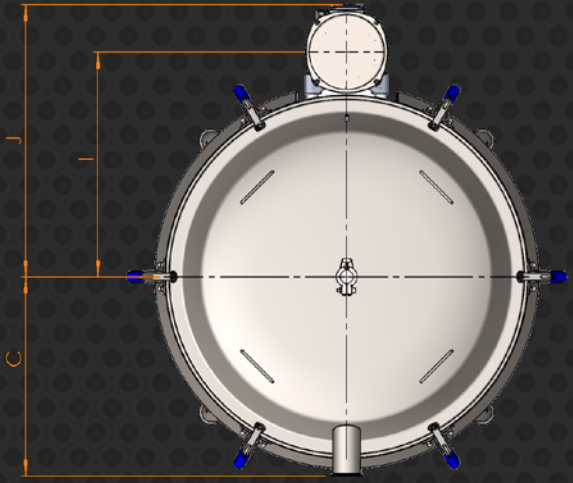

3

4

SM SLIMLINE 950 VS/PS

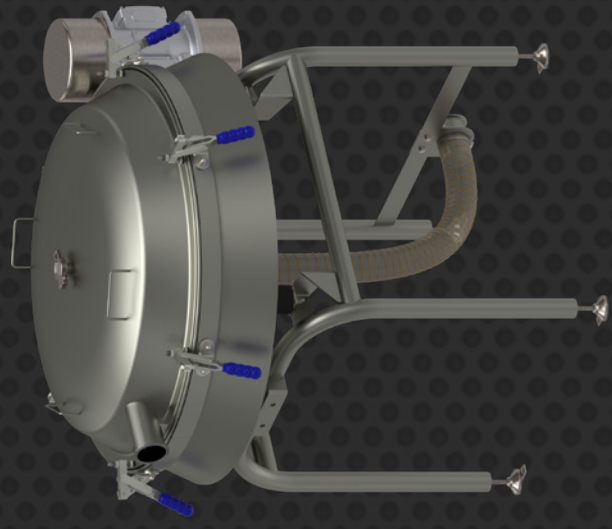

5

6

A

B

C

D

DIMENSION	SM 950 VS/PS
A	DN75 DIN32676
B	1106
C	550
D	DN75 DIN32676
E	250
F	431
G	1340
H	750
I	621
J	753
K	665

SCREEN DIAMETER = 965
 FRAMES FOR SM950 DIFFER FROM UNIT SHOWN - FOR GUIDANCE ONLY
 HOSE CONNECTIONS CAN BE MADE TO MATCH LINE

ELECTRICAL	SM 950 VS/PS
VOLTAGE	110-240 / 380-460
FREQUENCY	50 / 60 hz
POWER	0,35 kW
PHASE	1 / 3
ATEX	YES

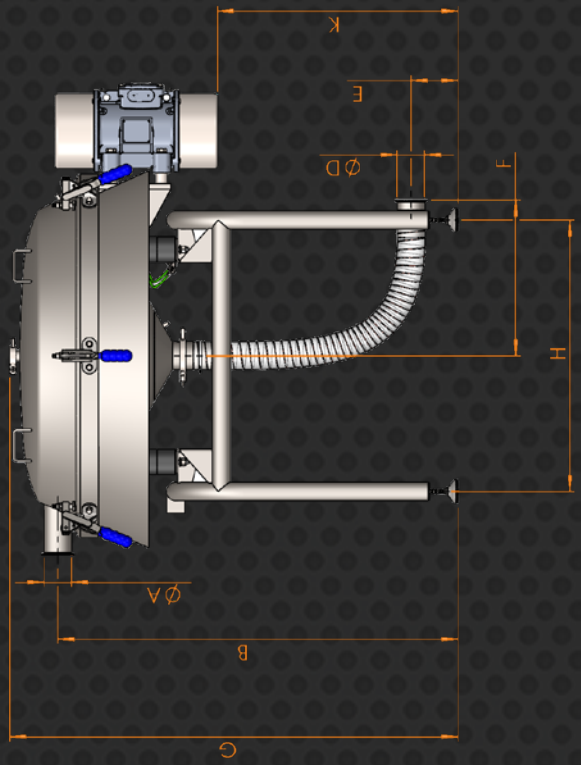

ALL DIMS. ARE APPROX. NOT TO BE USED FOR FINAL PLANNING. FULL DRAWINGS CAN BE SUPPLIED ON REQUEST. SUBJECT TO CHANGE AT ANY TIME.

1

THIRD ANGLE PROJECTION



2

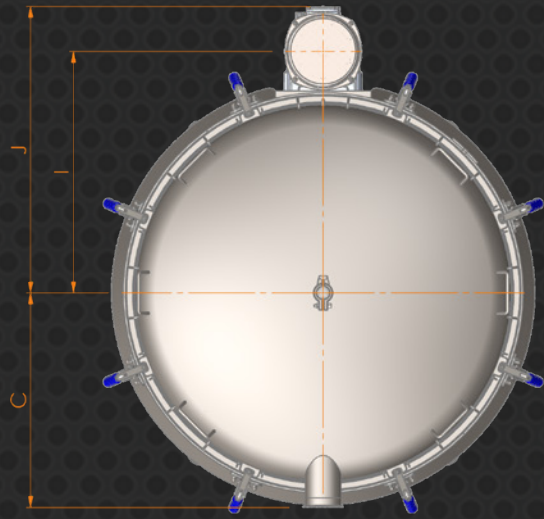

3

4

5

6

SM SLIMLINE 1250 VS/PS

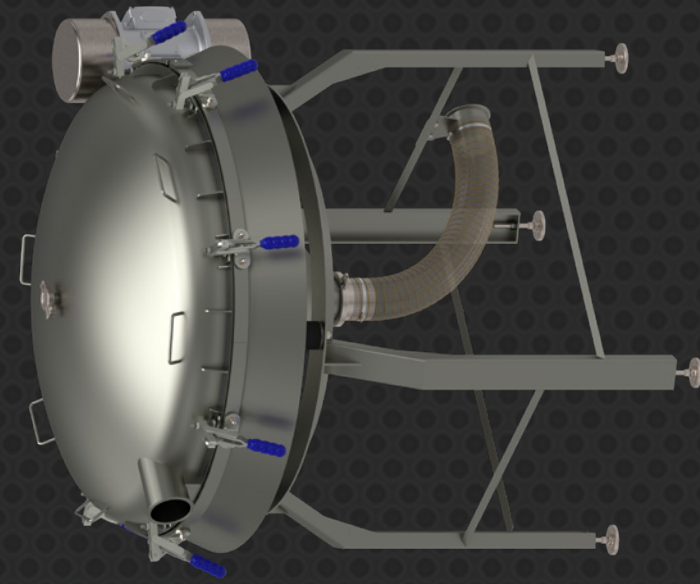

A

B

C

D

DIMENSION	SM 1250 VS/PS
A	DN100 DIN32676
B	1293
C	627
D	DN100 DIN32676
E	250
F	538
G	1492
H	930
I	706
J	838
K	844

SCREEN DIAMETER = 1169mm
 FRAMES FOR 1250 DIFFER FROM UNIT SHOWN - FOR GUIDANCE ONLY
 HOSE CONNECTIONS CAN BE MADE TO MATCH LINE

ELECTRICAL	SM 1250 VS/PS
VOLTAGE	110-240 / 380-460
FREQUENCY	50 / 60 hz
POWER	1.1 kW
PHASE	3
ATEX	YES

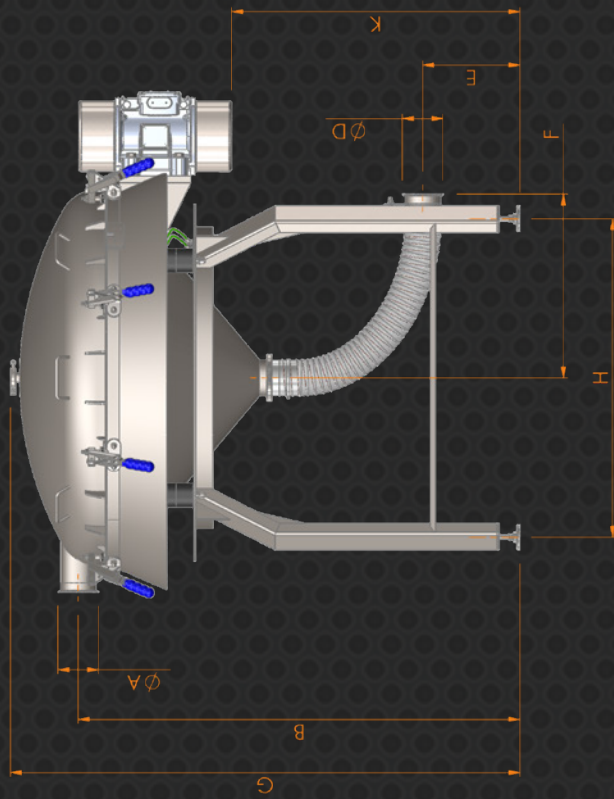

ALL DIMS. ARE APPROX. NOT TO BE USED FOR FINAL PLANNING. FULL DRAWINGS CAN BE SUPPLIED ON REQUEST. SUBJECT TO CHANGE AT ANY TIME.