



BULK INGREDIENT SOLUTIONS
FOOD



FO

FEEDING PRECISION. QUICK CLEANING.

Foods and their raw ingredients are sensitive products. Processing them requires continuous quality control, hygienic conditions, feeding precision with monitoring and absolute adherence to recipes and formulas. Brabender Technologie understands the needs of the food industry. Our feeding equipment enables you to process ingredients such as baby food, cake/bread mi-

xes or mueslis, as well as liquids like milk. The quick cleaning capability we provide enables you to easily work with a range of different recipes and formulas. Regardless of whether your manufacturing is continuous or batch-based – we have the right feeding system for your raw ingredients. Our Hygienic Design equipment enables you to make complex processes easy to handle.





FEED SCREWS

QUALITY

FEEDING

FOOD

POWDER

TRACEABILITY

PURITY

HYGIENIC

DESIGN

PRECISION

FEED CONSTANCY

EASY HANDLING

RAPID
CLEANING

Raw ingredients pose major food processing challenges. Natural ingredients are often very diverse as their size and shape are concerned. Let us take muesli mix as an example. Sugary dried fruits, for instance, are sticky, nuts can break and cane sugar or sucrose can agglomerate. Each individual ingredient has specific characteristics, while mixes can have completely different properties.



> PRACTICALLY MINDED

Chocolate is one of the most sensual of luxury foods. Many people just cannot imagine a life without this melt-in-the-mouth confectionery. Manufacturing it on an industrial scale is a genuine challenge, especially if bars have to be filled. If, for example, whole nuts have to be added to the basic mix consisting of cocoa powder, cocoa butter, sugar, full-cream milk and lecithin, this process requires substantial know-how. Brabender Technologie has developed a weigh-belt feeder for this specific purpose of adding nuts that is ideal for careful gravimetric feeding of all brittle bulk ingredients.

It is also capable of feeding many of the ingredients found in mueslis. Their basic ingredients, oat or similar flakes, do not represent a major feeding challenge. Yet as soon as so-called frosted (i.e. baked with sugar) flakes are involved, the feeding process becomes significantly more difficult. Sticky ingredients like these need vibration or stirring agitators to keep flowing, while degradation or damage to the particles must be avoided. Our Brabender FlexWall®Plus Feeder with a paddle-massaged flexible hopper, screw feeders with stirring agitators, vibrating tray feeders and DualTray mass flow feeders can be employed to do these jobs, for example.



SOLUTIONS TO AVOID HYGIENIC PROBLEMS



Closed components for easy cleaning

QUICK CLEANING

Strict hygienic standards apply to the food industry. Brabender Technologie partnered with leading food manufacturers to develop Brabender's Hygienic Design feeders while following the relevant food industry standards, guidelines and recommendations (DIN EN 1672-2, EHEDG, FDA etc.). We have created a range of equipment that is extremely easy to clean and that has specific design features to prevent any contamination. Some examples of these features include smooth stainless steel surfaces, non-porous full-penetration welds, elimination of cavities, radial edges and FDA-compliant ingredient contact materials.



Quick release fasteners for screws and screw tubes



Rounded edges and ground welds

> OUR SPECIALTY: LITTLE DEVILS

Dried fruits are healthy and delicious. But for manufacturers of mueslis, chocolate and cake/ bread mixes they can also be a problem. They stick together, lose juices when under pressure or are damaged, have poor flow properties and are inconsistent. Our Hygienic Design fruit feeders however will enable you to feed dried fruits into your product with precision and to the required standard of quality.



Soft consistency =
sensitive bulk ingredient





Every fruit has its own
unique consistency

Sugary dried fruits have a
tendency to stick together

Special fruit feeders made
by Brabender Technologie



FlexWall®Plus from above

FlexWall®Plus feeder

Twin screw feeder for very low feed rates

Congrav® operator interface

Blade screw

Single screw feeder

> MULTI-HERCULEAN-TASKING

Everything that you need. Digital and analog feeding technology, hygienic workmanship down to the smallest detail. Our diverse range of products masters the herculean task of providing the optimum feeder for every type of bulk ingredient used in the food industry.

Volumetric FlexWall®Plus



Bag dump hopper

Feeder downspout with quick release ring

Weigh-belt feeder

Spiral screw

Quick fastener

Twin concave screws

> DIVERSITY NECESSITATES GUIDANCE

Feeding, weighing, discharging and control are our core skills. To provide you with optimum guidance to the wide range of options we offer in various segments, we have branded our equipment in accordance with these segments. This enables you as a customer to identify all Brabender Technologie equipment straightaway and to categorize it according to requirements.

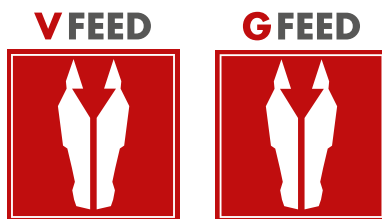

PREMIUM-FINISH FEEDERS

Our V-FEED and G-FEED brands provide you with a range of different volumetric and gravimetric feeders (according to volume or weight) to handle your bulk ingredients. Thanks to state-of-the-art technology and premium workmanship, these machines deliver maximum-accuracy results. All machines can be custom-enhanced at any time and adapted to meet modified production circumstances.

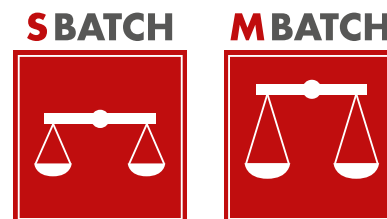

PRECISION WEIGH-BATCHING

Brabender Technologie offers a range of different solutions branded S-BATCH und M-BATCH for the automatic and accurate weigh-batching of bulk ingredient quantities. These facilitate single or multiple ingredient weigh-batching in accordance with the "loss-in-weight" or "gain-in-weight" principle.



RELIABLE DISCHARGE

D-CHARGE is the Brabender Technologie brand that covers a range of products for discharging your bulk ingredients. Be it bagged ingredients or ingredients from bulk bags, silos or other types of bin – our discharge aids enable you to discharge any kind of bulk ingredient with no hassle.

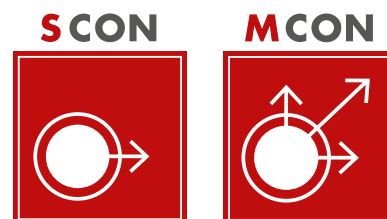

CONTROL SYSTEMS USING SMART SOFTWARE

The S-CON and M-CON brands are the control system solutions of Brabender Technologie. Be it single feeder or multiple feeder control systems, feeder-integrated or control cabinet-installed, thanks to our smart systems up to 16 feeders in a single process line can be controlled if required.



brabender
TECHNOLOGIE



The FlexWall®Plus loss-in-weight feeder feeds continuously or in batches in accordance with the loss-in-weight principle. This device is available with a Hygienic Design tubular weighing frame detail to meet food industry needs.

COMPONENTS FOR MAXIMUM HYGIENE



Hygienic Design motor



Hygienic Design junction boxes



Hygienic Design tubular weighing frame

FlexWall®Plus with tubular weighing frame

TECHNOLOGY OVERVIEW

There are Brabender Technologie devices for practically every application in the food industry. The various Hygienic Design feeders are complemented by S-CON- and M-CON-range controls. In addition to feeding and weigh-batching equipment, our portfolio also includes discharge aids for sacks, big bags, silos and bins.



FlexWall®Plus feeder with paddle-massaged flexible hopper

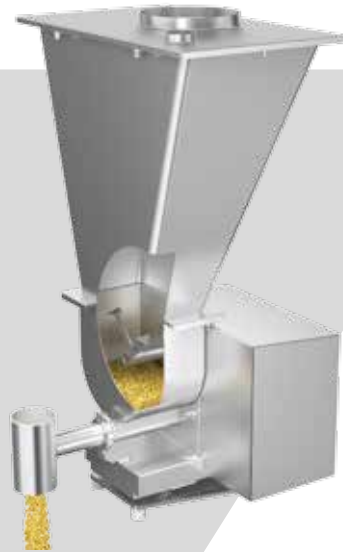

Screw feeder with stirring agitator



Vibration technology: vibrating-tray loss-in-weight feeder

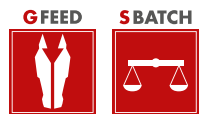

Twin screw feeder with stirring agitator



"MiniTwin"™ twin screw feeder for very low feed rates

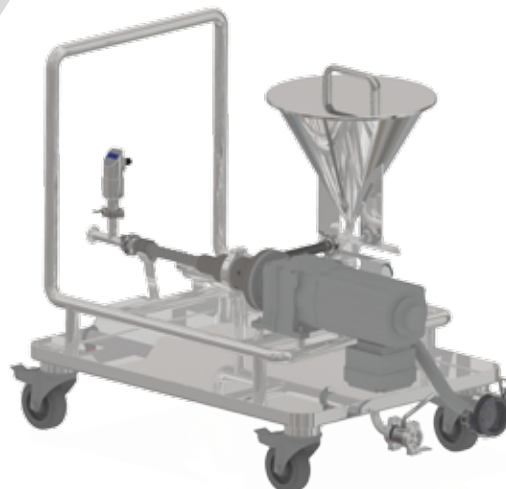

Liquid feeder

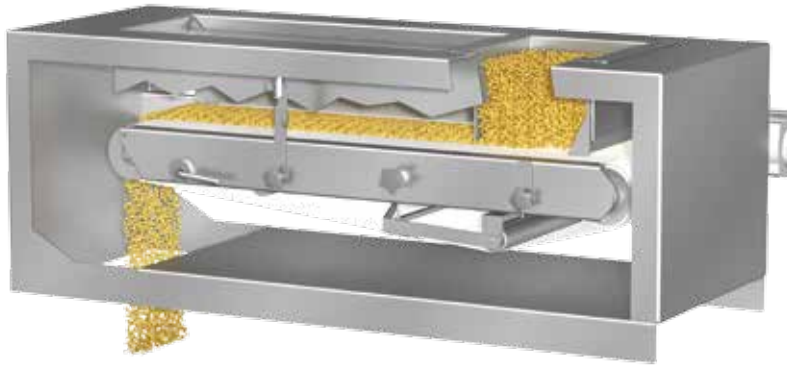

Weigh-belt feeder



"BagDumper" bag dump station



"DualTray" vibrating mass flow feeder



"BagMaster" bulk bag unloader



"BAV" vibratory bin activator for bulk ingredient discharge from silos and bins

> CLIENT-PLUS



Why not get in touch with us – we would be delighted to provide you with the advice you require. We help you to identify your specific needs and recommend the right equipment. You can test out how our feeders handle different bulk ingredients at our test labs. To enable you to use our equipment effectively at your production facilities, we train your staff on how to operate the machinery properly. Our maintenance agreements enable us to provide you with a practical, no-risk solution for long-term reliable use. If your production parameters change, we can help you search for a suitable solution.

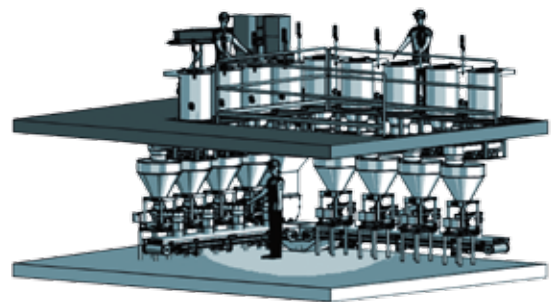

SERVICE



Twin screw



Pull-out belt frame



Remote maintenance and optimization



Operator interface



Screw replacement



Professional service

IN GOOD HANDS – FAST AND UNCOMPLICATED

You first become acquainted with our after-sales service, which we provide to you and your Brabender equipment when the machinery is commissioned. We will always provide you with a professional service, ranging from our Hotline via remote maintenance through service engineers visiting your premises. Our branches and service partners around the world enable us to offer you an extensive

customer service and stocking of all spare parts and consumable worldwide. Personal attendance by one of our service engineers to diagnose and eliminate a fault with one of your gravimetric feeders is not always necessary. In certain cases we can conveniently remote-access your microcomputer control system using the "TeamViewer" program, check the system and eliminate any faults or errors.



INTERNATIONAL

Brabender Technologie GmbH & Co. KG
Kulturstrasse 55-73
47055 Duisburg, Germany

Tel. +49 203 9984-0
Fax +49 203 9984-155
email@brabender-technologie.com
www.brabender-technologie.com

NORTH AMERICA

Brabender Technologie Inc.
6500 Kestrel Road, Mississauga
Ontario L5T 1Z6, Canada

Tel. 1-905-670-2933
Fax 1-905-670-2557
sales@brabenderti.com
www.brabenderti.com

PR CHINA

Brabender Technology (Beijing) Co., Ltd.
3rd F, B Section, No. 3 Workshop, 2nd Project
of Guanglian Industrial Park, No. 2 Kechuang
East 5th Rd., Opto-Mechatronics Industrial Park
Tongzhou, Beijing 101111, China

Tel. +86-10-8150-4087/-4121, Fax -4301
hongjun.yang@brabenderbeijing.com

RUSSIA

ООО „Service Vostok“
1-st Tshipkovsky per. H20
Office 109
115093 Moscow, Russia

Tel. +7 (499) 235 73 95
service@servicevostok.ru

INDIA

Brabender Technologie GmbH & Co. KG
(Indian Branch Office)
BE-86, Sector-I (2nd & Gr. Floor)
Salt Lake City, Kolkata - 700064, India

Tel. +91 33 2358-7784/-7789
Fax +91 33 2358-7791
anup.biswas@brabender-technologie-india.com

MIDDLE EAST

Brabender Technologie Middle East
P.O. Box 18139
Dubai, United Arab Emirates

Tel. +971 (0) 4 887 09 50
Fax +971 (0) 4 887 03 44
Mobile +971 (0) 5 064 04 176
kbigham@brabender-technologie.com

Keep the Flow



